

# Model 100LX Specifications and Dimensions

## STANDARD FEATURES:

- 1 HP, 115/230 volt, 50/60 Hz, single phase, explosion proof motor (see below for starters and controls).
- Unit operates at 4850 rpm.
- Mixing head is raised and lowered by a hand crank mechanism.
- Type 316 stainless steel wetted parts.
- Sturdy frame for bench mounting.
- All non-stainless steel external surfaces coated with a white two part epoxy paint.
- Easy to completely disassemble and clean with simple hand tools.

## AVAILABLE MIXING ATTACHMENTS\*:

- **LX Attachment:** High Shear Rotor/Stator attachment, complete with disintegrating, slotted, fine screen and axial-flow stator heads. Attachment is equipped with a glass filled Teflon bushing.
- **ILX Attachment:** Inline attachment complete with disintegrating, slotted, fine screen and axial flow stator heads.
- **DLX Attachment:** High speed disperser attachment.

## AVAILABLE OPTIONS:

- Down-thrust propeller for standard Rotor/Stator attachment.
- Bronze or solid Teflon bushings or Stellite bushing and shaft (for abrasive applications) for standard Rotor/Stator attachment.
- Vessel/Beaker clamp attachment.
- 1 HP 230/460 volt, three phase, explosion proof motor (can be used with optional inverter for variable speed operation).
- 2 HP 230/460 volt, three phase, explosion proof motor (can be used with optional inverter for variable speed operation).
- Controls such as inverters, motor starters, or explosion proof operators stations are available (voltage, frequency and type of enclosure must be specified).

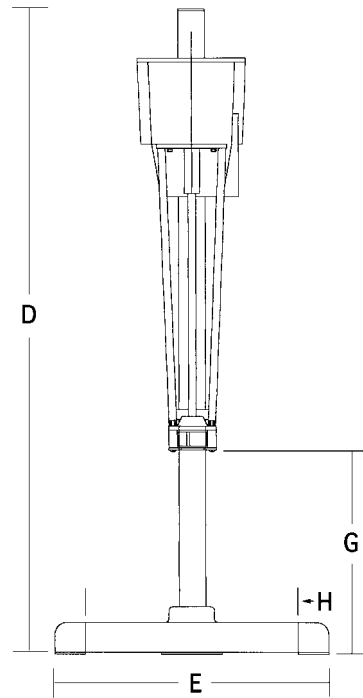

(clearance under mixing attachment with mixing head in raised position)

(LX Attachment Shown)

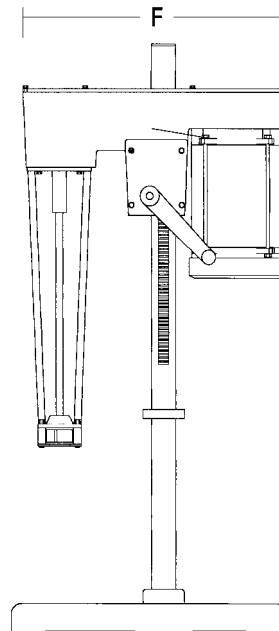

Model Series 100	HP	RPM	D O.A. Height		E O.A. Width		F O.A. Length		G (LX attachment)		G (ILX attachment)		G (DLX attachment)		H Distance between feet		Capacity (water)		Weight	
			"	mm	"	mm	"	mm	"	mm	"	mm	"	mm	"	mm	Gal.	Ltr.	Lbs.	Kgs.
100LX	1	4850	40 1/2	1029	130	58	21	533	19 15/16	490.5	10 7/8	276.2	18	457.2	14	355.6	1 to 5	4 to 19	130	58

\* See back of this sheet for dimensions of attachments.

HSM LX SS-00



**CHARLES ROSS & SON COMPANY**

P.O. Box 12308, 710 Old Willets Path, Hauppauge, NY 11788 • Fax: 1-631-234-0691 • Tel: 1-631-234-0500

Website: [www.mixers.com](http://www.mixers.com) • Email: [sales@mixers.com](mailto:sales@mixers.com)

# Model 100LX Attachments

**LX Attachment  
(standard rotor/stator)**

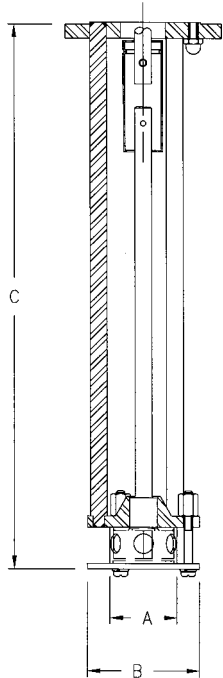

*round hole  
disintegrating  
(included)*



*fine screen (included)*



*slotted (included)*

**ILX Attachment  
(inline)**

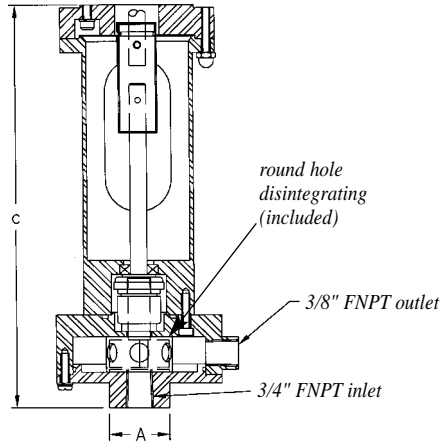

*round hole  
disintegrating  
(included)*

*3/8" FNPT outlet*

*3/4" FNPT inlet*



*fine screen (included)*



*slotted (included)*

**DLX Attachment  
(high speed disperser)**

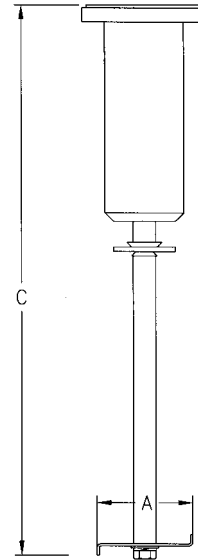

Attachment	A Rotor Diameter		B Lower Flange		C Shaft Length	
	inches	mm	inches	mm	inches	mm
LX	2	50.8	3 1/8	79.4	19 3/8	492.1
ILX	2	50.8	N/A	N/A	10 7/8	276.2
DLX	3*	76.2	N/A	N/A	18	457.2

\* A 3" dia. disperser blade is supplied with this attachment. Consult factory for information on other available sizes.



**CHARLES ROSS & SON COMPANY**

P.O. Box 12308, 710 Old Willets Path, Hauppauge, NY 11788 • Fax: 1-631-234-0691 • Tel: 1-631-234-0500

Website: [www.mixers.com](http://www.mixers.com) • Email: [sales@mixers.com](mailto:sales@mixers.com)