

Series 700 Direct-Driven Specifications and Dimensions

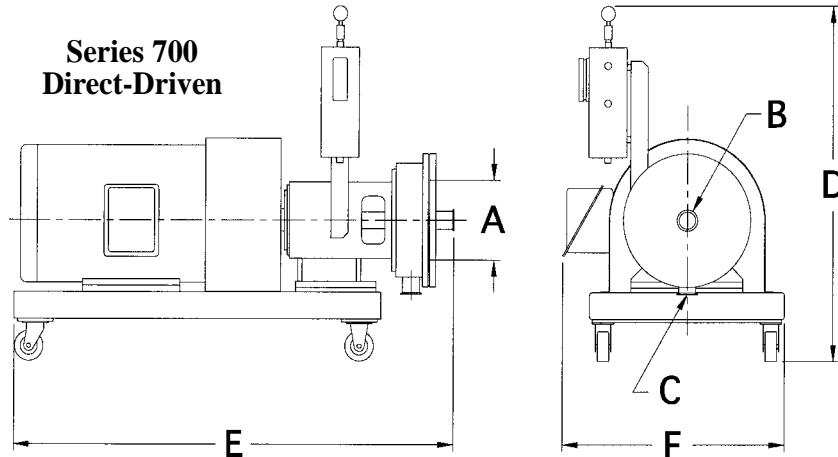

STANDARD FEATURES:

- 40 through 300 HP.
- 230/460 volt, 60 Hz., three phase, explosion proof motors (see options for starters and controls).
- Tip speeds of 11,300 feet per minute.
- Heavy-duty shafts and bearings as well as extremely tight machining tolerances.
- X-Series or Quad Slot rotor/stator sets.
- Equipped with a cartridge type double mechanical seal and barrier system.
- Type 316 stainless steel wetted parts.
- NPT threaded connections on units through 10 HP. Larger units use standard ANSI flanges.
- All non-stainless steel external surfaces coated with a white two part epoxy paint.

AVAILABLE OPTIONS:

- Higher tip speeds up to 18,000 feet per minute can be obtained by using special inverter duty motors.
- Extra heavy duty bearings and forced oil cooling for continuous processing of high viscosity materials.
- Special motors including, inverter duty, wash-down and stainless steel as well as special voltages and frequencies are available.
- Special double mechanical or gas-purged seals available.
- Sanitary designs with special seals, polished components and sanitary connections available.
- Jacketed mixing chamber for heating or cooling.
- Portable carts mounted on casters are available in either carbon or stainless steel.
- Skid mounted recirculating systems including vessel, piping and valves.
- Controls such as inverters, motor starters, or explosion proof operators stations are available (voltage, frequency and type of enclosure must be specified).

Series 700	Rotor/Stator	HP**	RPM	A Rotor Dia.		B Inlet Size		C Outlet Size		D O.A. Height		E Direct O.A. Length		F O.A. Width		Weight	
				"	mm	"	mm	"	mm	"	mm	"	mm	"	mm	Lbs.	Kgs.
703	*	*	*	*	*	*	*	*	*	*	*	*	*	*	*	*	*
706	*	*	*	*	*	*	*	*	*	*	*	*	*	*	*	*	*
709	X or Quad Slot	40-100	4800	9	229	2	51	1 1/2	38	54	1374	60	1527	30	763	2200	1375
712	X or Quad Slot	50-150	3600	12	305	3	76	2	51	60	1527	78	1985	36	916	2400	1500
715	X or Quad Slot	75-250	2880	15	382	4	102	3	76	60	1527	84	2138	36	916	2750	1710
718	X or Quad Slot	100-300	2400	18	458	6	153	4	102	60	1527	90	2290	42	1069	3200	2000

* These models are available in belt-driven versions only, please refer to other side of this sheet.

**Dimensions and weights are based on lowest horsepower motor for each model. Consult factory for dimensions and weights of other horsepower.

HSM 700D SS-00



CHARLES ROSS & SON COMPANY

P.O. Box 12308, 710 Old Willets Path, Hauppauge, NY 11788 • Fax: 1-631-234-0691 • Tel: 1-631-234-0500

Website: www.mixers.com • Email: sales@mixers.com

Series 700 Belt-Driven Specifications and Dimensions

STANDARD FEATURES:

- 10 through 300 HP.
- 230/460 volt, 60 Hz., three phase, explosion proof motors (see below for starters and controls).
- Tip speeds of 11,300 feet per minute.
- Heavy-duty shafts and bearings as well as extremely tight machining tolerances.
- X-Series or Quad Slot rotor/stator sets.
- Equipped with a cartridge type double mechanical seal and barrier system.
- Type 316 stainless steel wetted parts.
- NPT threaded connections on units through 10 HP. Larger units use standard ANSI flanges.
- All non-stainless steel external surfaces coated with a white two part epoxy paint.

AVAILABLE OPTIONS:

- Higher tip speeds up to 18,000 feet per minute can be obtained either by changing the ratio of the pulleys, or by using special inverter duty motors.
- Lower speeds and greater torque can be provided by changing the ratio of the pulleys for very high viscosity applications.
- Extra heavy duty bearings and forced oil cooling for continuous processing of high viscosity materials.
- Special motors including, inverter duty, wash-down and stainless steel as well as special voltages and frequencies are available.
- Special double mechanical or gas-purged seals available.
- Sanitary designs with special seals, polished components and sanitary connections available.
- Jacketed mixing chamber for heating or cooling.
- Portable carts mounted on casters are available in either carbon or stainless steel.
- Skid mounted recirculating systems including vessel, piping and valves.
- Controls such as inverters, motor starters, or explosion proof operators stations are available (voltage, frequency and type of enclosure must be specified).

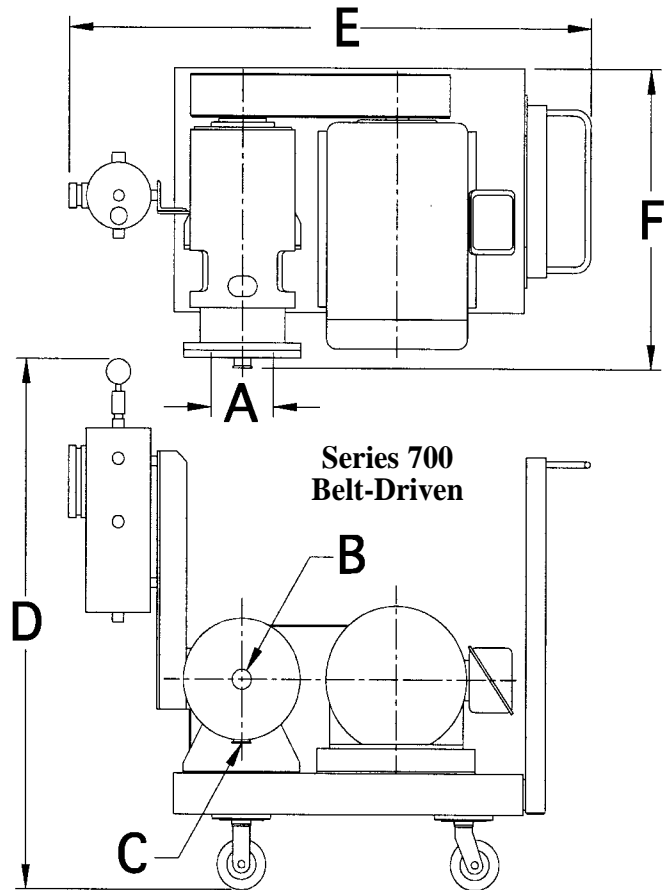

Series 700	Rotor/Stator	HP**	RPM	A		B		C		D		E		F		Weight	
				Rotor Dia.	Inlet Size	Outlet Size	O.A. Height	Belt O.A. Length	O.A. Width	Lbs.	Kgs.						
703	X or Quad Slot	10-40	15000	3	76	3/4	19	1/2	13	45	1145	34	865	28	712	500	312
706	X or Quad Slot	30-75	7200	6	153	1 1/2	38	1 1/2	38	54	1375	54	1374	30	763	2000	1250
709	X or Quad Slot	40-100	4800	9	229	2	51	1 1/2	38	54	1375	54	1374	30	763	2200	1375
712	X or Quad Slot	50-150	3600	12	305	3	76	2	51	60	1527	72	1832	42	1069	2400	1500
715	X or Quad Slot	75-250	2880	15	382	4	102	3	76	60	1527	72	1832	42	1069	2750	1710
718	X or Quad Slot	100-300	2400	18	458	6	153	4	102	60	1527	78	1985	48	1222	3200	2000

**Dimensions and weights are based on lowest horsepower motor for each model. Consult factory for dimensions and weights of other horsepower.

HSM 700B SS-00



CHARLES ROSS & SON COMPANY

P.O. Box 12308, 710 Old Willets Path, Hauppauge, NY 11788 • Fax: 1-631-234-0691 • Tel: 1-631-234-0500

Website: www.mixers.com • Email: sales@mixers.com